

# Cannon Boiler Works, Inc.

## Feedwater Heaters



*Unique boiler economizer designed to recover your boiler stack energy and save you thousands of dollars a year*



## UNIT COMPARISON CHART

Feature	Feedwater Heaters	2-Inch Economizers
Removable tubes	The tubes are removable without the need to torch cut or ASME weld. The tubes are connected with a compression style fitting.	Tubes are removable. However, the casing will need to be torch cut to have access to tube ends. Then, each tube will need to be torch cut. The remaining tube ends will need to be weld prepped. All work must have the approval of the boiler inspector.
Tube pull access	The feedwater heater has a bolted on, removable end panel for easy tube removal. (FB unit has welded end panel.)	The economizer has a welded end box (Optional removable end box doors are available.)
Bottom transitions	Included in the base unit price. Available in optional heavy duty and stainless steel upgrades.	Not supplied with the economizers. Usually supplied in field by the installing contractor. (Can be supplied by Cannon as optional equipment.)
Collection baffles and dams	Standard on all feedwater heaters.	Not included. Normally field designed and fabricated (if used at all).
Tube material	Standard available in carbon steel, stainless steel, duplex stainless steel and AL6XN stainless steel. (FB unit available in duplex stainless steel only.)	Available in carbon steel.
Design pressure	450 PSIG heat exchanger. Low gas side pressure drop.	600 PSIG is standard. Higher pressures are available.
Side access doors	Both sides of the feedwater heater are removable. (FB unit has welded end panel.)	The sides are not removable. (Optional 16" x 16" access door is available.)
ASME stamping	ASME Section VIII Division 1 with upgrade to Section I available. CRN Registration.	Section I standard.
Fin material	Carbon steel standard. Can be upgraded to stainless steel. (FB unit available in stainless steel only.)	Available in carbon steel only.
Nickel brazed tubes	Standard on all feedwater heaters.	Standard on all economizers.
Applicable boiler size	Fits boilers from 40 HP thru 7,000 HP. Works well on firetube and watertube boilers.	Fits boilers from 500 HP and larger. Typically used on watertube boilers.
Insulation	2"-thick, high-temperature fiberglass standard. None included with FB unit. (Provided in field by others.)	3"-thick, high-temperature fiberglass standard.
Modular design	The feedwater heater comes in seven model styles and in sizes 3 through 36.	Each unit is custom designed for your application.

One-piece tube elements are easily disengaged and removed for service. Tubes are available in Carbon Steel, Stainless Steel and Duplex Stainless Steel, with Carbon and Stainless Steel fins. Several other materials are available for custom applications. Tubes are normally in stock with next day delivery available.



### Standard feature

Base price includes carbon steel inlet and outlet transitions.

### Standard feature

Rigid steel frame is built to support tube core, with removable panels and transition.

### Standard feature

Insulated side doors and end panels are easily removable. No welding required for closing. Stainless steel lined.



### Standard feature

Both ends of the header are threaded or flanged for easy plumbing. No ASME code welders required for repairs.

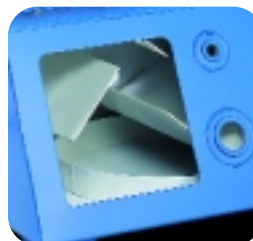

### Standard feature

Bottom transition has a water collection system composed of baffles and drains preventing leakage into the boiler and damage to your refractory.





**FB Series**

Applications  
Firetube 40 HP-125 HP



**FS Series**

Applications  
Firetube 80 HP-500 HP



**FJ Series**

Applications  
Firetube 400 HP-2,000 HP  
Watertube to 150,000 pph



**FG Series**

Applications  
Firetube 200 HP-2,000 HP  
Watertube to 150,000 pph

**F3J, F3G and  
FK Series**

Larger units are now available in the F3J series, F3G series and FK series. These feedwater style units are custom designed for watertube boiler applications up to 150,000 pph of water flow.

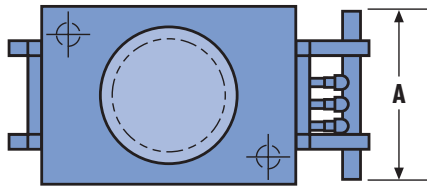

PLAN VIEW

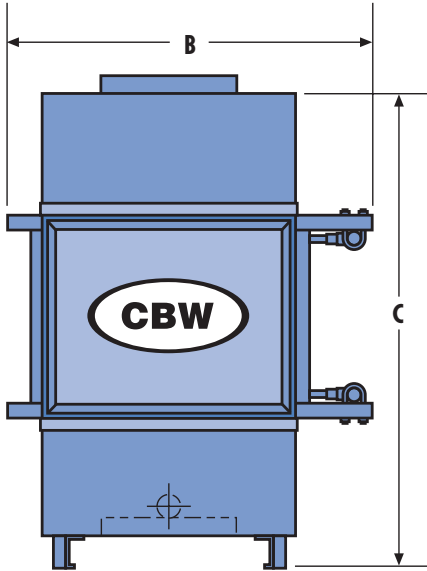

ELEVATION VIEW



**Call Today for a Performance and Payback Quotation**

**SIZING AND DIMENSIONAL DATA FOR FEEDWATER HEATERS**

FWH MODEL NO.	FB	FS-3	FS-4	FS-5	FS-6	FS-8	FS-10	FS-12	FS-14	FS-16	FS-18	
Dimensions (in)												
"A"	15-1/4	24-9/16	27-3/4	30-15/16	34-1/8	40-1/2	46-7/8	53-1/4	59-5/8	66	72-3/8	—
"B"	36	53-1/2	53-1/2	53-1/2	53-1/2	53-1/2	53-1/2	53-1/2	53-1/2	53-1/2	53-1/2	—
"C"	40	72-11/16	72-11/16	72-11/16	72-11/16	72-11/16	72-11/16	72-11/16	72-11/16	72-11/16	72-11/16	—
Weight (lb)	300	690	760	850	940	1105	1235	1405	1560	1715	1870	—
Boiler Size Range (HP)	40-125	50-125	75-250	100-350	150-400	200-600	300-900	400-1100	500-1200	600-1400	600-Up	—
FWH MODEL NO.	FJ-4	FJ-5	FJ-6	FJ-8	FJ-10	FJ-12	FJ-14	FJ-16	FJ-18	FJ-20		
Dimensions (in)												
"A"	27-3/4	30-7/8	34-1/8	40-1/2	46-7/8	54	60-3/8	66-3/4	73-1/8	79-1/2	—	—
"B"	92-1/16	92-1/16	92-1/16	92-1/16	92-1/16	92-1/16	92-1/16	92-1/16	92-1/16	92-1/16	—	—
"C"	82-5/8	82-11/16	82-5/8	82-11/16	86-11/16	86-11/16	86-11/16	86-11/16	86-11/16	86-11/16	—	—
Weight (lb)	1480	1650	1820	2155	2590	2860	3210	3550	3900	4250	—	—
Boiler Size Range (HP)	200-600	350-800	400-1100	500-1200	600-1400	700-1500	800-1800	900-2000	1000-3000	1000-Up	—	—
FWH MODEL NO.	FG-4	FG-5	FG-6	FG-8	FG-10	FG-12	FG-14	FG-16	FG-18	FG-20	FG-22	FG-24
Dimensions (in)												
"A"	27-3/4	30-15/16	34-1/8	40-1/2	46-7/8	54	60-3/8	66-3/4	73-1/8	79-1/2	85-7/8	92-1/4
"B"	67	67	67	67	67	67	67	67	67	67	67	67
"C"	98-1/16	98-1/16	98-1/16	98-1/16	102-1/16	102-1/16	102-1/16	102-1/16	102-1/16	102-1/16	102-1/16	102-1/16
Weight (lb)	1300	1400	1550	1855	2200	2805	3110	3395	3675	3955	4255	4520
Boiler Size Range (HP)	200-600	350-800	400-1100	500-1200	600-1400	700-1500	800-1800	900-2000	1000-3000	1000-3000	1000-Up	1000-Up

Consult factory for larger F3J, F3G, FK models or custom unit sizes.

# The Cannon Feedwater Heater

***Engineered for Exceptional Performance, Construction, and Maintenance***

## **Recycle Waste Heat and Produce Substantial Savings**

In today's economy, reducing operating costs will be necessary for survival. Equipping your boiler with a Cannon Feedwater Heater will provide the most efficient operation.

## **Compact Construction**

The Cannon Feedwater Heater is a compact and durable box-type unit constructed to rugged boiler standards. This is not a disposable unit like many other designs, and will last as long as your boiler.

## **Rigid Steel Construction**

The rigid steel frame is built to support the tube core, removable panels, the inlet and outlet transition and a stack of reasonable height. The frame is designed so that the unit can be

supported overhead, avoiding any undue structural loads on your boiler outlet.

## **Performance**

Cannon's high-performance Feedwater Heater will extract heat from your boiler stack gases. This heat is then returned directly to the water feeding the boiler, considerably reducing your fuel costs. Our ASME feedwater heater core features extended surface finned tube elements.

## **Removable Panels**

The Feedwater Heater has removable panels on each side and one end for easy inspection and cleaning, if necessary. All four sides of the unit are insulated with panel-type construction and feature a stainless steel interior for added corrosion resistance.

## **Performance Guarantee— Cannon Boiler Guarantees the Thermal Performance on All Units**

***The Closer You Look, the More Value You'll Discover***

Look at true value, as well as cost, and you'll find a Cannon Feedwater Heater is a worthwhile investment for both you and the environment.

Cannon's wide selection of units allows you to match a gas side pressure drop and maximize heat recovery on your boiler system. ***Our units are designed for low gas side pressure drop in order to retain peak boiler performance.*** An efficient boiler saves energy and burns less fuel, resulting in reduced emissions and the satisfaction of contributing to a cleaner environment.

Cannon Feedwater Heaters pay for themselves by reducing your fuel bills. When you order a Cannon Feedwater Heater, we'll provide you with the estimated payback schedule based on your boiler plant. Most applications see an installed payoff in less than two years. Cannon Feedwater Heaters are designed to be

repairable—not disposable. Unlike coiled units where the loss of a coiled tube means the loss of the unit, Cannon Feedwater Heaters contain a series of individual tubes, each one easily replaceable. Since Cannon manufactures its own finned tubing—the heart of any heat exchanger—you can be assured it always meets our strict quality control measures. By brazing helical-wound fin to the tube, we can produce a void-free, smooth profile without violating the tube wall as a welded attached fin would.

Cannon's wide selection of materials allows you the opportunity to maximize your heat recovery. The Cannon unit is designed with the additional advantage of being able to heat low-temperature make-up or process water as well as deaerated feedwater. The greater the temperature difference, the higher your heat recovery.

# Other Products Available From Cannon

## **Standard-Duty Economizers**

The Cannon standard-duty 2-inch economizer is designed with an open-lattice that allows the flue gases access to the return bend area. This design is recommended for use with clean burning fuels. The open-end box design offers a lower initial cost.

## **Heavy-Duty Economizers**

Our heavy-duty 2-inch economizer is recommended for use with gas, oil or coal. It is designed with bulkhead tube sheets and special drawn steel gas seals to isolate the cooler return bend area from the gas stream. The gas seals prevent the buildup of soot and fly ash from accumulating in the end box where soot blowing will not clean and dramatically reduces the risk of corrosion.

## **Finned Tube Products**

Cannon manufactures custom finned tubes in similar and dissimilar metal combinations for gas to liquid services, and are available from prototype quantities to full-scale monthly production runs.

## **Waste Heat Boilers**

Whether your waste heat is generated by gas turbine, incinerator, diesel engine, or another source, Cannon has the extensive experience required to create a saturated steam, super-heated steam or hot water system. A thorough analysis of conditions of

the waste heat temperature, temperature consistency, combustion by-products, pressure and flow rates enables us to custom-design and build a highly efficient waste heat recovery system.

## **Direct-Fired Super Heaters**

Direct-fired super heaters are an economical way to provide high-temperature steam without expensive boiler retrofit or the need for high-pressure boilers. They are designed for operation independent of your steam boiler with full steam capacity or partial loads for your particular process.

## **Vent Condensers**

Vent condensers are used to eliminate unsightly steam plumes and recover your wasted energy. They are particularly suited for use with a deaerator.

## **Intercoolers and Aftercoolers**

Cannon offers complete reconditioning programs for both finned tube and bare tube units.

## **Specialty Manufacturing**

We will package our standard equipment with related auxiliaries to provide complete design, engineering, system manufacturing and testing at one location. Skid-mounted packages are available.



**Cannon Boiler Works, Inc.**

510 Constitution Boulevard • New Kensington, PA 15068  
Voice: 724.335.8541 • Fax: 724.335.6511 • E-mail: [sales@cannonboilerworks.com](mailto:sales@cannonboilerworks.com)  
[www.cannonboilerworks.com](http://www.cannonboilerworks.com)