



800-228-8861
502-968-2211
rental.sales@wareinc.com
www.wareinc.com

STOCK EQUIPMENT

WARE Offers New/Used Equipment In Stock

BOILER INFORMATION

Manufacturer Victory Energy
Year 2018
Type Saturated Steam
Capacity 400 HP / 13,800 PPH
Pressure 150 PSI
Burner Powerflame CM10A-GO-30

CONNECTION SIZES

Main Steam 8" 300# Flanged
Natural Gas 4" NPT
#2 Oil 1" NPT
Feedwater 2" NPT
Bottom Blowdown 1-1/2" NPT
Continuous Blowdown 1-1/2" NPT

FUEL CONSUMPTION

Natural Gas 16,740 SCFH
#2 Oil 121 GPH

CONTROLS

Honeywell 7800 Series

ELECTRICAL POWER REQUIREMENTS

480V, 3 Ph, 60 Hz

EMISSIONS DATA

NOx .036# / mmBtu w/17% FGR
SO2 .001# / mmBtu
CO .15# / mmBtu
PM .008# / mmBtu

BOILER OVERALL DIMENSIONS & WEIGHT

Length/Width/Height 319" / 95" / 105"
Shipping Weight 28,750 lbs
Operating Weight 48,690 lbs

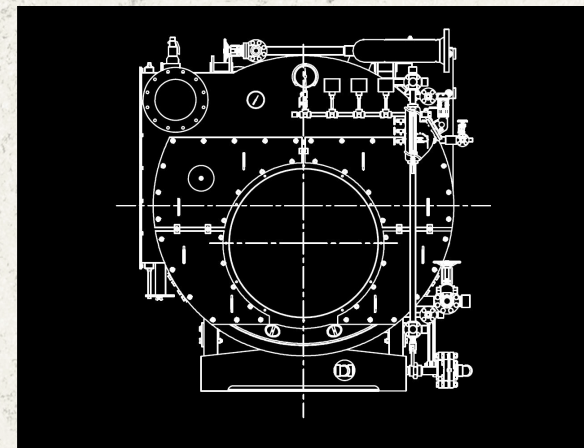

ADDITIONAL INFORMATION

SB-243
Model: F3-DB-576C-400-S150-SB

Firetube Boiler, 3-Pass, Dryback,
400 BHP, 150 psig with a Powerflame
Natural Gas & #2 Oil burner system.
Burner has a 6:1 turndown ratio and is
rated for 16.74 mmBtu gas input.

Package meets UL & CSD-1 codes.

The boiler is offered with a one (1) year parts and motors warranty (less labor) and the pressure vessel is guaranteed to pass an ASME inspection.