



STEAM GENERATORS



# **PACKAGED STEAM GENERATORS**

THE CIRCULATIC® LINE

**VAPOR POWER** INTERNATIONAL



# CIRCULATIC® STEAM GENERATORS

## Recirculating Water Tube Units:

Steam from: 75 BHP to 600 BHP (2,580 to 20,700 PPH)  
Pressure from: 15 PSIG - 530 PSIG

The Circulatic® steam generator is available in capacities up to 600 BHP and has a compact footprint saving you space. In less than 5 minutes the Circulatic can go from a cold start to full output and is available in design pressures required for your industry.

The Circulatic is also ideal for retrofit applications since our 500 BHP can fit in less space than a 300 BHP firetube boiler. A smaller footprint means savings on construction costs, not to mention the quick response to load changes which provides flexibility for industrial and commercial applications.

For over a century, our company has been serving the needs of a wide range of industries that require steam. We have earned a reputation as the premier designer and manufacturer of boilers, steam generators and liquid phase heaters used worldwide.

## USER BENEFITS

- **RAPID START UP**  
From cold start to full load in five minutes
- **LOW INSTALLATION COSTS**  
Packaged, compact units require only half of the floor space needed for firetube boilers
- **QUICK RESPONSE TO LOAD CHANGES**  
Cycle time of less than 30 seconds
- **LONG LIFE & MINIMUM MAINTENANCE**  
Coil design pressure of 1000 psig results in thicker coil walls for longer life
- **MAXIMUM SAFETY**  
Steam drum located outside of firing zone
- **HIGH QUALITY STEAM**  
Guaranteed 99%+ dry steam
- **MINIMUM ON-OFF CYCLING**  
Turndown ratios up to 10 to 1 for handling wide range of loads
- **MINIMUM PREPURGE ENERGY LOSS**  
Compact size allows proper prepurge in seconds
- **LOW FUEL REQUIREMENTS**  
Air preheating and combustion zone for complete combustion
- **EASY INSTALLATION**  
Skid mounted assembly including control panel
- **SIMPLIFIED FUEL SWITCHING**  
Only have to turn selector switch, no burner changes required
- **MINIMAL SOOT POTENTIAL**  
Separate combustion chamber prevents coating coils with partially burned fuels
- **COMPLETE LINE**  
Eleven sizes to permit proper selection for any application



## APPLICATIONS

- Asphalt & Liquid Terminals
- Brewery & Distillation
- Corrugated & Paper Manufacturing
- Food Processing
- Healthcare & Commercial Facilities
- Oil & Gas Processing
- Power Plant
- Process Steam & Heat
- University & Institutional Facilities

# CIRCULATIC® FLOW DIAGRAM

The Circulatic® is a forced recirculation watertube boiler that uses a drum as a steam separator and a reservoir of water to supply the coils. A recirculating pump draws the water from the drum and forces it through a set of parallel connected coils at the rate of 3 to 4 times the maximum steaming rate. The hot gases envelop the entire tube surface to achieve very high heat transfer rates.

The water is then pushed through a steam lance and a series of baffles in the drum where some of the water is flashed into steam and separated. The dry steam is released and the water is recirculated through the coils. The fuel and combustion air is controlled by a linkageless fuel air ratio control that responds to steam pressure. The feedwater is controlled by a water level control system and modulating feedwater valve.

99%+ dry steam is withdrawn from the drum and the water forms a reservoir of heat saturated water to feed the recirculating centrifugal pump

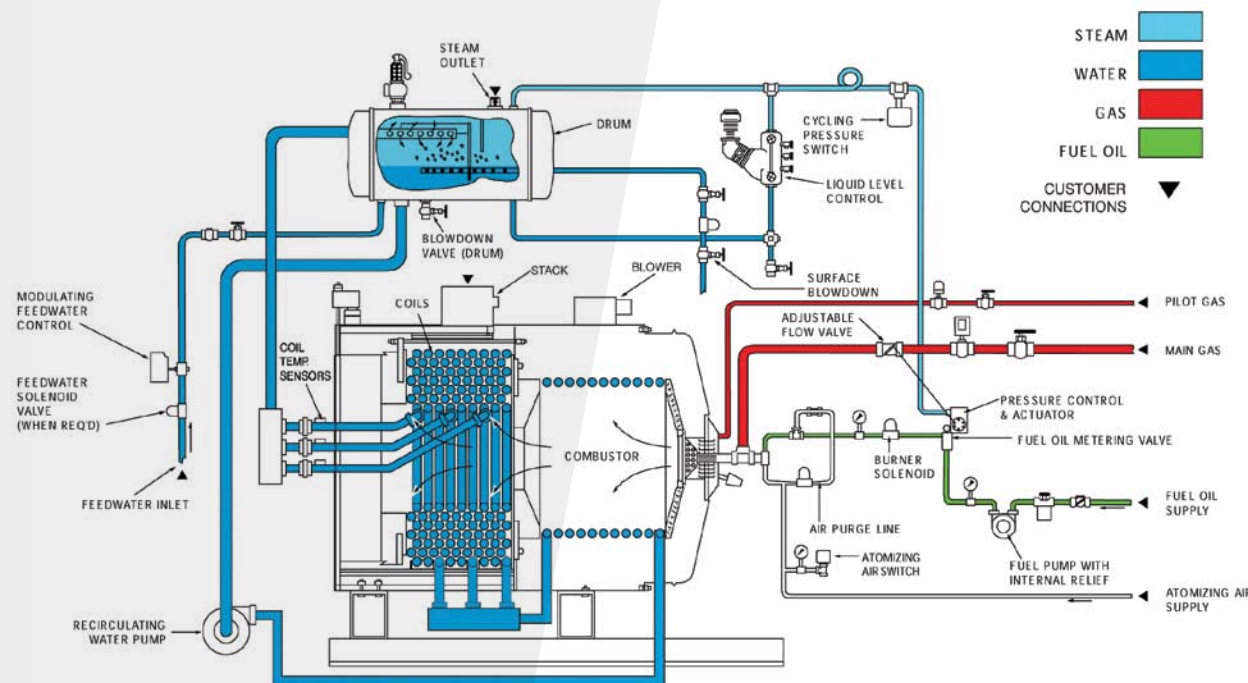

## Integral Control Panel

A factory wired control panel contains all controls and indicators necessary for the safe operation of the unit. A programmed operating sequence is also incorporated for simplified startup. Available equipment includes linkageless burner controls, touch screen controls interface, variable speed combustion air blower, oxygen trim, remote communication and data acquisition, and more.

## Built to Meet Standards

Every unit is built to ASME Standards, Hartford inspected and National Board registered. CSA, Coast Guard, American Bureau of Shipping, Factory Mutual, Lloyds and other approvals are also available upon request.

## Factory Tested

All units are fire tested at the factory, with their individual controls to assure proper operation and to allow for control adjustments which avoid installation delays.

## Features

- Full Steam in 5 Minutes
- Fully Modulating Output
- Compact Size & Weight
- High Pressure
- Safe Operation



# CIRCULATIC® SPECIFICATIONS

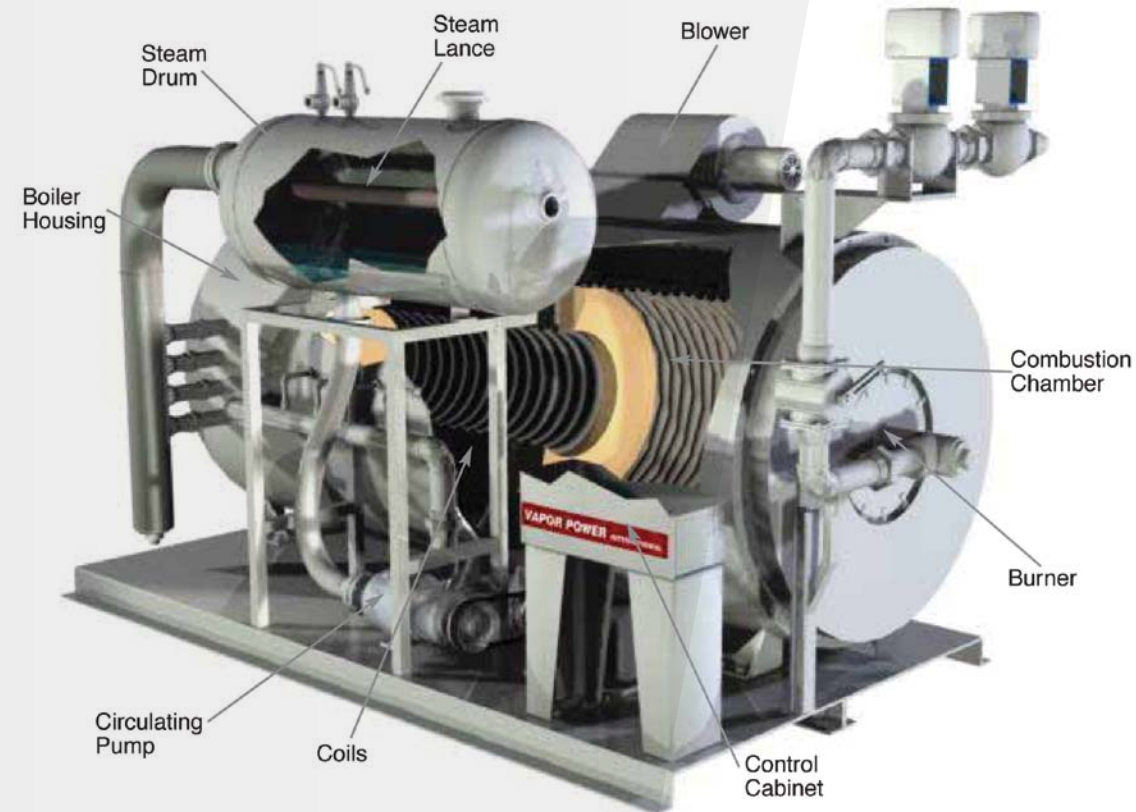

**BOILER TYPE:** Multiple parallel coil, watertube type, forced circulation, forced draft fired.

**BURNERS:** Air atomized burner for #2 fuel oil. Multi-orificed burner for natural gas or LPG. Burners available to meet low NOx and ultra-low NOx regulations.

**IGNITION:** Electric spark ignited, interrupted gas pilot on most units. Direct electric spark optional on #2 oil units where permitted.

**SAFETY CONTROLS:** Programmed flame safeguard control with flame detector, coil temperature control, low water cut-off control and steam pressure control.

**OPERATING PRESSURES:** Adjustable throughout operating range based on design pressure. Consult factory for special operating pressure ranges.

**ELECTRIC POWER:** Main - 230, 460, or 575 VAC, 3 Ph, 60 HZ. Control - 120 VAC, 1 Ph, 60 HZ, factory wired. Special voltages are available on request.

**OPTIONAL EQUIPMENT:** Automatic Blowdown, Stack Switch, Automatic Multiple Boiler Control, Annunciator Systems and equipment to meet special exacting codes.

# DATA AND DIMENSIONS

Rated Capacity BHP	Equivalent Evaporation PPH from & at 212°F	Thermal Capacity Btu's/hr x 1000	Design Pressure psig	Approx. Fuel Consumption ♦			Dimensions Inches			Approx. Shipping Weight lbs
				Oil GPH	IMP Gal.	Gas CFH	L	W	H	
75	2,580	2,510	15-530	22.0	18.3	3,138	104	78	90	5,300
100	3,450	3,350	15-530	29.3	24.4	4,188	110	78	96	5,800
150	5,175	5,025	15-530	44.0	36.7	6,281	120	78	96	7,700
200 ★	6,900	6,700	15-530	58.7	48.9	8,375	122	92	107	9,800
250 ★	8,625	8,370	15-530	73.3	61.1	10,463	130	92	107	11,900
300 ★	10,350	10,050	15-530	88.0	73.3	12,563	130	92	107	11,900
350 ★	12,075	11,725	15-530	102.7	85.6	14,656	142	92	107	13,000
400 ★	13,800	13,400	15-530	117.3	97.8	16,750	151	92	107	15,500
450 ★	15,525	15,075	15-530	132.0	110.0	18,844	155	92	116	17,500
500 ★	17,250	16,750	15-530	146.7	122.2	20,938	168	92	116	18,300
600 ★	20,700	20,100	15-530	176.0	146.7	25,125	180	119	144	36,000

♦ Based on #2 fuel oil at 141,000 Btu/U.S. gal. and natural gas at 1000 Btu/cu.ft. heat content

★ Available with heavy oil combustion system

## Commissioning & Training

Vapor Power can provide complete commissioning as well as hands-on, or classroom training about the complete operation of your equipment.

## Troubleshooting & Diagnostics

Vapor Power offers remote access and monitoring of your equipment.

## Parts & Service

Vapor Power stands behind its products with original OEM parts, no matter the age of the equipment. We also offer direct factory training and service on-site.

# AFTER MARKET

As one of the industry's leading manufacturers of boilers, packaged steam generators and thermal fluid heaters, Vapor Power International has everything you need to keep your boilers operating in top condition. That includes complete retrofit upgrade kits to outfit your boilers with the latest in controls and components.

- Air-cooled Pump
- Combustion Coil Upgrade Kit
- Control Panels
- Feedwater and Drum Level Controls
- Flame Safeguard Controls
- Linkageless Controls
- Temperature Controls



**VAPOR POWER** INTERNATIONAL

**551 S. County Line Rd.  
Franklin Park, IL 60131**

**P: 630.694.5500**

**F: 630.694.2230**

**VaporPower.com**

