



ELECTRIC BOILERS

ELECTRODE BOILERS
WITH JET-FLO® TECHNOLOGY

VAPOR POWER INTERNATIONAL

ELECTRODE BOILERS

Electrode Steam Boilers

Steam from: 3000 kW to 34,000 kW (10,000 to 113,000 PPH)
Pressure from: 100 – 500 PSIG
Voltages from: 4160 – 14,400 Volts

Hot Water Boilers with similar capacities are also available

The Electrode Steam Boiler with Jet-Flo® technology consists of an insulated pressure vessel and is fully enclosed in 18 gauge enameled steel panels. There is no heat transfer through tube walls and there will never be tube failures from excessive wall temperature, poor water treatment, or fireside corrosion, since there are no tubes to fail! Heat transfer takes place directly in the water in the steam chamber, thus producing high quality steam of 99.95% purity throughout the operating range.

A Vapor Power electrode steam boiler offers a great hybrid boiler room solution, taking advantage of off peak power rates. Fossil fuel fired boilers and the electrode boiler are automatically rotated based on real time power costs, maximizing steam plant efficiency. Electrode steam boilers are available in sizes from 3,000 to 34,000KW, 10,000 to 113,000 PPH, supply voltage of 4,160 to 14,400 volts, and offer efficiencies greater than 99%.

ADVANTAGES

- **HIGH EFFICIENCY**
Greater than 99%
- **HIGH TURNDOWN & QUICK RESPONSE TO LOAD CHANGES**
Safely operate as low as 1% of output
- **RELIABLE SOURCE OF STEAM**
For areas affected by oil and/or gas shortages, or where coal is either low grade or not available
- **NO MOVING PARTS**
Eliminates downtime due to packing leaks around the hydraulically-operated shield positioning system that is present on other designs. No risk of failure of internal mechanical shields. No hydraulic system required.
- **LOW INSTALLATION COST**
Eliminates need for special boiler room, fuel handling and storage equipment, air handling equipment, preheaters and/or economizers, stacks, flues and emission control equipment, ash handling and disposal facilities, combustion safety systems, noise abatement equipment, plus space and installation costs associated with aforementioned equipment.
- **NO EMISSIONS**
Makes for an easy installation because no air permits are required
- **LABOR SAVINGS**
Electric boilers in most states are classified as “unfired steam generators” and as such do not require full operator attendance
- **NO DIELECTRIC BARRIERS NEEDED**
- **NO SPECIAL WATER TREATMENT**
- **INDUSTRIAL GRADE COMPONENTS**

APPLICATIONS

- Brewery & Distillation
- Container & Paper Processing
- Healthcare Facilities
- Power Plant
- Process Steam & Heat
- University & Institutional Facilities

ELECTRODE BOILERS

The Vapor Power electrode boiler creates operating advantages from its unique design which results in a high efficiency, high quality steam boiler. Using electricity as a clean, efficient and easily controlled fuel, all the energy input to the boiler is converted to steam with 99% efficiency. Vapor Power's electrode boiler output is controllable from 0-100%, with neither the limited turndown ratios nor the increasing inefficiency at low output conditions characteristic of fossil-fired boilers. There are no stacks to purchase and there are zero pollutant emissions.

The simplicity of electrode controls and engineered boiler design results in significantly reduced maintenance. With no moving parts within the boiler, there is less maintenance associated with our units. Even under the conditions of feedwater loss, for example, the electrode boiler is fail-safe as low water in itself affects boiler shutdown, precluding catastrophic failure. There is no heat transfer through tube walls and there will never be tube failures from excessive wall temperature, poor water treatment, or fireside corrosion, since there are no tubes to fail. Heat transfer takes place directly in the water in the steam chamber, thus producing high quality steam of 99.95% purity throughout the operating range.

AVAILABLE POWER: With the electric boiler set at a slightly higher pressure than parallel fossil fueled boilers, sensing plant demand, and limited to a maximum plant demand set point, competitively priced available power can be consumed to effect a flat demand curve.

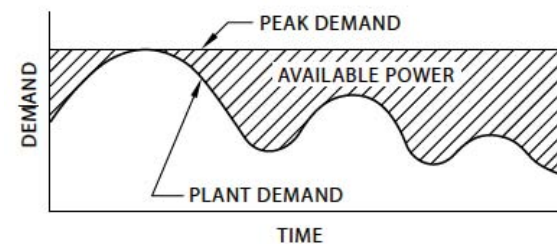

By using a 2-element control system, the electric boiler would either generate as much steam as allowed by the demand control system or, when steam demand is below what the electric boiler is allowed to generate, be limited by the steam pressure control to a preset steam pressure.

Using electricity as a clean, efficient and easily controlled fuel, all the energy input to the boiler is converted to steam with 99% efficiency

Controls

The electrode boiler is locally managed by a PLC-based system that controls every aspect of the boiler which includes control of water level, steam pressure and KW limit. All safety devices will also be monitored by the PLC. Interface to the PLC by an operator is accomplished through an HMI device that communicates directly with the boiler PLC. Remote data acquisition and control is available via ModBus, Ethernet, Bacnet, or other communication protocol.

Built to Meet Standards

Every unit is built to ASME Standards, Hartford inspected and National Board registered. Other approvals are also available upon request.

Hot Water Option

To generate hot water, Vapor Power offers a steam-to-water heat exchanger attached directly to the boiler. Outputs available range up to 170,000 MBTU/Hr. The advantage of this system is that the condensate from the heat exchanger flows by gravity back to the boiler eliminating the need for a condensate return or deaerator system, which also improves the system efficiency.



EXTERNAL PUMP BOILERS

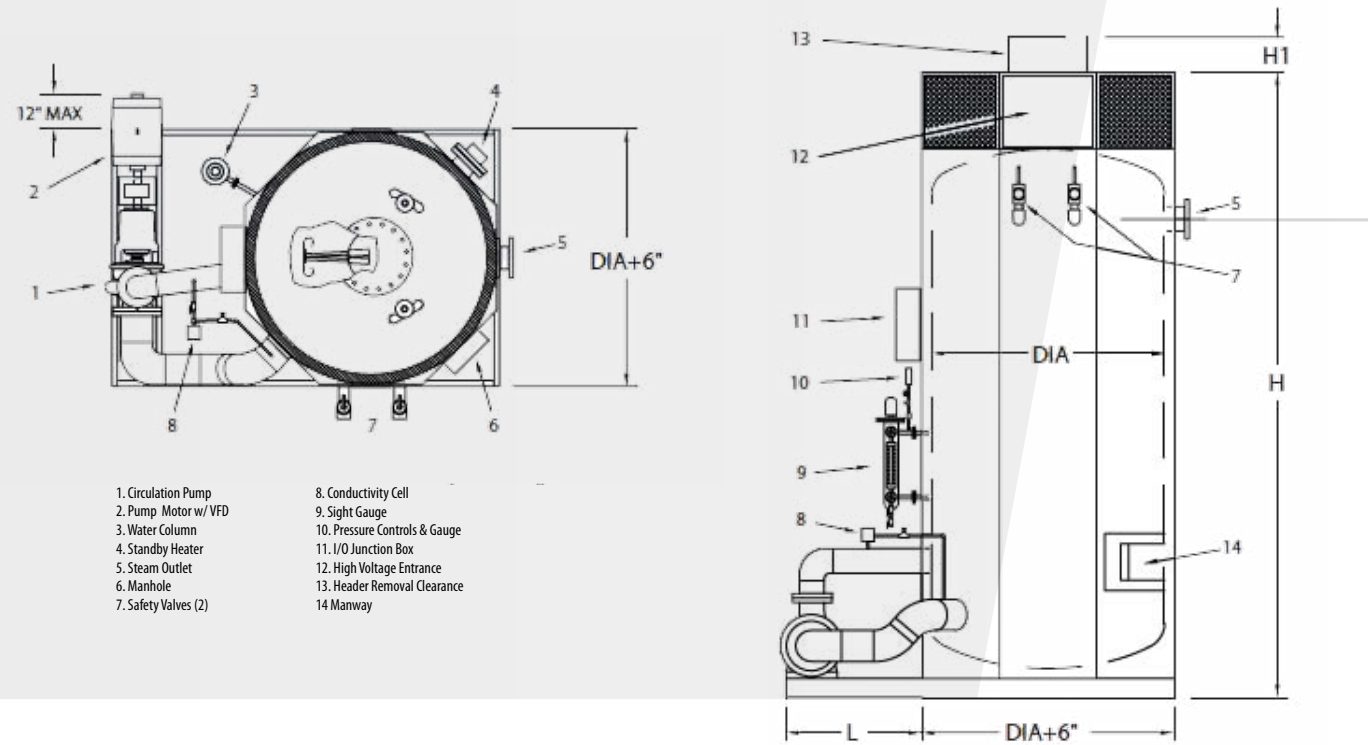

Model Number	Nominal Rating*** (KW)			Nominal Rating*** (PPH)			Number of Electrodes	Dimensions (inches) @ 13.2KV				Weight (Lbs)****		
	4160V	6.9KV	13.2KV	4160V	6.9KV	13.2KV		Dia	H	H1	H2	Ship	Operate	Flooded
BBJ-300	800	1700	3000	2700	5700	10000	3	60	152	6	30	8500	1300	19700
BBJ-450	1300	2500	4500	4300	8300	15000	3	60	172	16	30	9700	13000	22400
BBJ-600L**	1700	3400	6000	5700	11300	20000	3	60	168	24	66	10300	13600	23400
BBJ-600	1700	3400	6000	5700	11300	20000	3	60	186	24	30	10800	14300	24100
BBJ-750L**	2100	4200	7500	7000	14000	25000	3	60	186	32	84	11300	14800	25500
BBJ-750	2100	4200	7500	7000	14000	25000	3	60	200	32	36	11700	15400	26100
BBJ-840L**	2400	4700	8400	8000	15700	28000	3	60	194	38	84	11900	15800	27300
BBJ-840	2400	4700	8400	8000	15700	28000	3	60	210	38	36	12400	16500	28000
BBJ-1050L**	3000	5900	10500	10000	19600	35000	6	66	180	20	84	12300	15800	28100
BBJ-1050	3000	5900	10500	10000	19600	35000	6	66	196	20	36	12700	18200	30600
BBJ-1200L**	3400	6700	12000	11300	22300	40000	6	66	186	24	84	12700	16600	28900

* All of these models utilize external ANSI standard circulation pumps
 ** Low headroom application, at a premium price - two circ. pumps provided side by side
 *** Ratings are for operation at 150 psi with 220 Degrees Fahrenheit Feedwater
 **** Weights are for 175psi design pressure

INTERNAL PUMP BOILERS

1. Blowdown Valves
2. Pump Removal Clearance
3. Circulation Pump w/ VFD
4. Check Valve (for 2-pump boilers only)
5. Conductivity Cell
6. Sheet Metal Lagging
7. Insulation
8. Safety Valves (2)
9. Electrode Terminal Enclosure
10. Conduit Entrance Panel
11. Header Removal Clearance
12. Conductor Rod
13. High Voltage Insulators
14. Back Pressure Regulator
15. Steam Outlet
16. Non-Return Valve
17. Insulator Shields
18. Electrode / Strike Plate
19. Nozzle Header
20. Counter Electrode
21. Pressure Manifold & Pressure Gauge
22. Water Column & Sight Gauge
23. Surface Blowoff
24. Standby Heater
25. Feedwater Regulator
26. Manhole
27. Top Cover

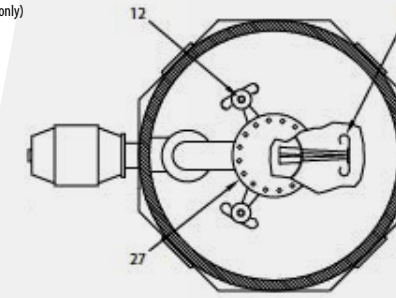

PARTIAL TOP VIEW

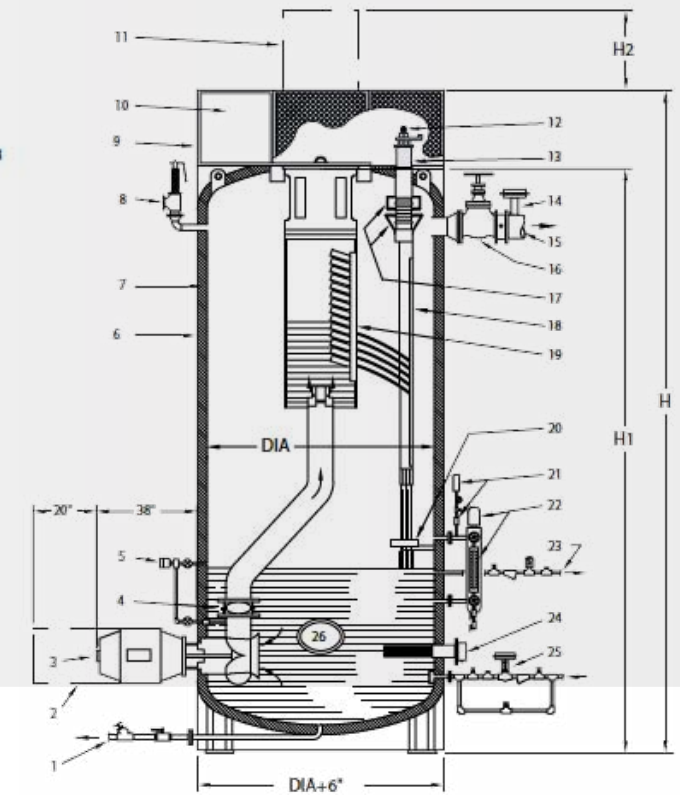

Model Number	Nominal Rating** (KW)			Nominal Rating** (PPH)			Number of Electrodes	Dimensions (inches) @ 13.2KV				Weight (Lbs)***		
	4160V	6.9KV	13.2KV	4160V	6.9KV	13.2KV		Dia	H	H1	H2	Ship	Operate	Flooded
BBJ-1200	3400	6700	12000	11300	22300	40000	6	72	218	194	24	15500	21400	34600
BBJ-1500	4200	8500	15000	14000	28300	50000	6	72	232	208	32	16500	23800	36700
BBJ-1650	4700	9200	16500	15700	30600	55000	6	72	242	218	38	17500	25400	39500
BBJ-1800	5100	10100	18000	17000	33600	60000	9	84	237	210	21	20000	32000	50000
BBJ-2150	6100	12000	24500	20300	40000	72000	9	84	253	226	29	21000	34000	54000
BBJ-2550*	7200	14300	25000	24000	47600	85000	9	84	245	218	35	23000	33000	53000
BBJ-2400*	6800	13400	24000	22600	44600	80000	12	96	236	206	18	24500	40000	67000
BBJ-3000*	8500	16800	30000	28300	55900	100000	12	96	252	222	26	26500	43500	72000
BBJ-3400*	9600	19000	34000	32000	63300	113000	12	102	264	234	32	30000	51500	85000

* These models utilize 2 internal pumps
 ** Ratings are for operation at 150 psi with 220 Degrees Fahrenheit Feedwater
 *** Weights are for 175psi design pressure

VAPOR POWER INTERNATIONAL

**551 S. County Line Rd.
Franklin Park, IL 60131**

P: 630.694.5500

F: 630.694.2230

VaporPower.com

