



brands you trust.



CRANE® - Cast Steel Valves



Crane ChemPharma & Energy

www.cranecpe.com

Features & Benefits



Key Features & Benefits

- 1 All seat rings are seal welded as standard
- 2 Quality process fully documented, materials fully traceable
- 3 Full range of special trims and options available

Typical Industries and Applications

- **Energy** - Power Production, Oil & Gas, Refining, District Heating
- **Processing** - Chemical Processing, Pulp & Paper, Food & Beverage, Petro Chemical
- **Other Industries** - Marine, Waste Water, Mining, OEM, others

Performance in Any Application

In any fluid handling system, valves are the controlling element: starting or stopping flow, regulating or throttling flow, preventing backflow, or relieving and regulating pressure.

Since Crane valves are used in a variety of applications, the following descriptions may provide a basic guideline in the selection of steel valves.

Gate Valves

Gate valves serve as efficient stop valves with flow in either direction. They are commonly used where a minimum pressure drop is important. Throttling is not recommended because partially open gate valves exhibit flow characteristics not conducive to accurate and consistent flow control. Also, the valves may be damaged by the high velocity across the seats. They function best fully open or fully closed.

Gear Actuators recommended for Gate valves:

- Class 150: sizes above 10"
- Class 300: sizes above 8"
- Class 600: sizes above 6"

Globe Valves

Globe valves are ideal for throttling service. Their flow characteristics permit accurate and repeatable flow control. However, caution must be exercised to avoid extremely close throttling when pressure drop exceeds 20%. This creates excessive noise, vibration and possible damage to valves and piping. Crane does not recommend applications in excess of this due to possible damage to the valve.

Gear Actuators recommended for Globe valves:

- Class 150: sizes above 6"
- Class 300: sizes above 6"
- Class 600: sizes above 4"

Swing Check Valves

Swing Check valves prevent reversal of flow through pipe lines. Most Crane swing check valves can be installed in horizontal or vertical, upward flow, piping. They offer low resistance to flow and are particularly suited to low velocity service.

Tilting Disc Check Valves

Tilting Disc Check valves are similar to swing check valves. In most installations, slamming is minimized upon reversal of flow so noise and vibration are reduced.

Stop Check Valves

High-Pressure Boiler Stop check valves are essentially the same as globe and angle valves, except there is no mechanical connection between the stem and disc. However, they are not designed for throttling. They are used in steam boiler outlet piping when two or more boilers are connected to a common header. Valves must be installed with pressure under the disc, and when the stem is raised, only boiler pressure can raise the disc, whenever boiler pressure exceeds header pressure. They prevent steam backflow from the header to the boiler.

Typical Bolted Bonnet Gate Valve Features

Crane gate valves offer the ultimate in dependable service for steam, air, gas, oil, oil vapor, and high pressure installations. All have straight-through ports to assure minimum turbulence,

1. Body: Body is cast to provide liberal strength to meet operating conditions and to permit unobstructed flow. Turbulence, erosion and pressure drop are minimized. Flanged End-Crane cast steel gate valves are available in flanged end and butt weld ends. All flanged and butt welding end valves are designed to conform to ASME B16.5 and ASME B16.34 standards.
2. Integral Yoke & Bonnet: Some designs incorporate a two-piece bonnet and yoke. All bonnet assemblies are cast and finished to the same exacting tolerances as the bodies for accurate alignment of stems and ease of sealing. Bonnet joint varies from flat face gasket-joint to ring-type bonnet joint, depending on class.
3. Seat Rings: Seat rings are seal welded to eliminate leak path behind rings and for long trouble-free service. The surfaces are precision ground to fit accurately with the disc.
4. Disc: Crane's one piece flexible disc provides accurate alignment of mating seating surfaces so the valve can absorb piping strains without leakage. Also, it avoids any tendency to stick in the seated position.
5. Stem: The tee-head disc-stem connection prevents lateral strain on the stem for smooth, easy operation. Accurately cut threads engage the yoke sleeve for positive control of disc position.
6. Yoke Sleeve
7. Handwheel Nut
8. Yoke Sleeve Retaining Nut
9. Packing: Packing contains corrosion inhibitor to avoid stem pitting. Stuffing box is deep, assuring long packing life.
10. Gland: Gland is a two-piece ball-type which exerts even pressure on the packing without binding the stem.
11. Gland Flange
12. Gland Eye Bolts: Eyebolts swing aside for ease in repacking the stuffing box.
13. Gland Eye Bolt Nuts
14. Bonnet Gasket
15. Bonnet Studs: Number is dependent on valve size and class.
16. Bonnet Nuts: Number is dependent on valve size and class.
17. Gland Eyebolt Pins
18. Bonnet Bushing
19. Handwheel: Crane gate valves can also be supplied with gear or motor operators.
20. Hydraulic Grease Fitting: Hydraulic grease fitting provides for lubrication of yoke sleeve bearing surfaces (not shown).

erosion, and resistance to flow. They are available in a wide variety of trims.

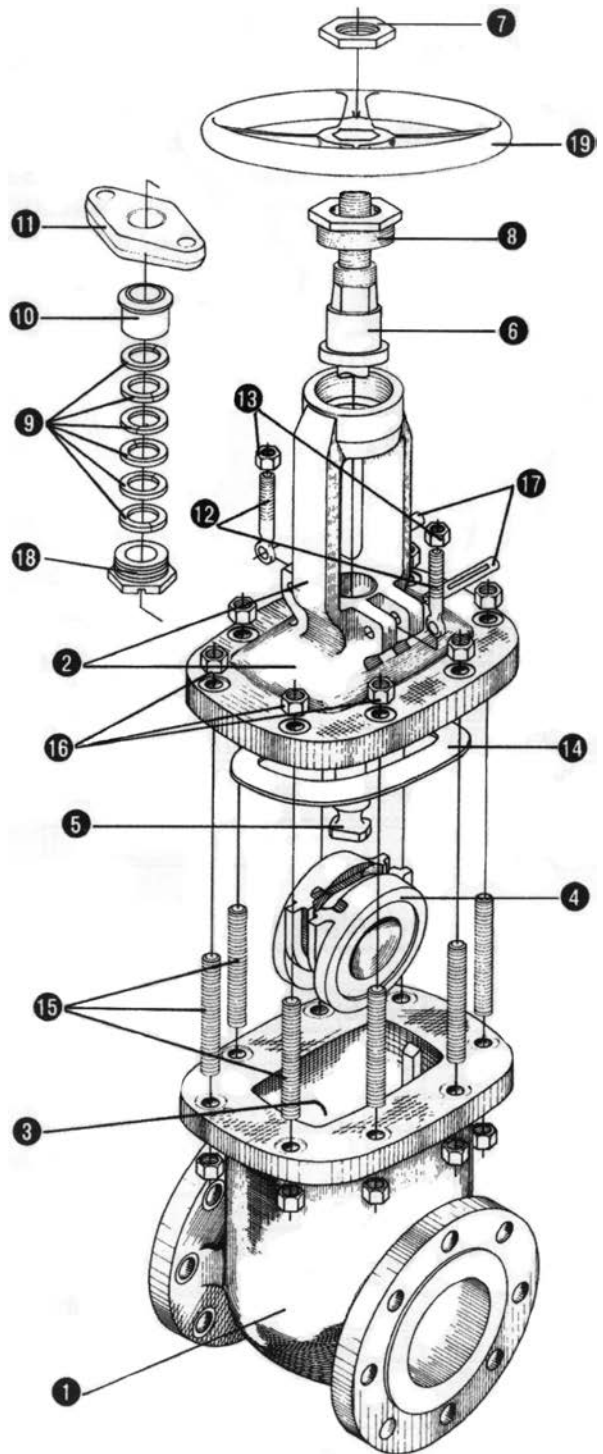

NOTE: Crane recommends the use of gear assistance for certain multi-turn valves for optimal functional performance in larger sizes and high flow-rate applications. Please refer to the note on specific product pages in the Crane Cast Steel Technical Datasheet.

Typical Globe Valve Features

Crane globe valves are highly efficient for services requiring frequent operation and throttling when pressure drop across the valve is about 20% of inlet pressure. Closer throttling, creating higher pressure drops may cause cavitation or excessive velocities which could cause high noise levels, vibration and possible damage to the valve or adjacent piping.

Globe valves can be equipped with optional operators and are available with a variety of trims to match service requirements. Crane globe valves are supplied as standard with contour or spherical type plugs and are classified as quick opening on flow curves.

1. Body: Body is cast with heavy sections reinforced at points subjected to the greatest stress. Valves are available in both flanged and butt welding ends. All conform to ASME specifications.
2. Bonnet
3. Seat Ring
4. Disc
5. Disc Stem Nut: Disc Stem Ring connects the disc to the stem, permitting the disc to swivel and aid in securing tight seating for trouble-free service.
6. Disc Washer
7. Stem: Stem has long engagement with yoke bushing for accurate seating.
8. Bonnet Bushing
9. Yoke Bushing
10. Wheel Nut
11. Packing
12. Gland: Gland is a two-piece, ball-type which exerts even pressure on the packing without binding the stem.
13. Gland Flange
14. Gland Eye Bolts: Eye bolts are securely fastened to the bonnet yet swing away to permit easy access to the stuffing box.
15. Bonnet Gasket: Bonnet gasket provides a positive seal against leakage. Class 150 and 300 valves have a male/female bonnet joint. A ring-type gasket is employed in Class 600.
16. Bonnet Studs
17. Bonnet Nuts
18. Pin
19. Handwheel

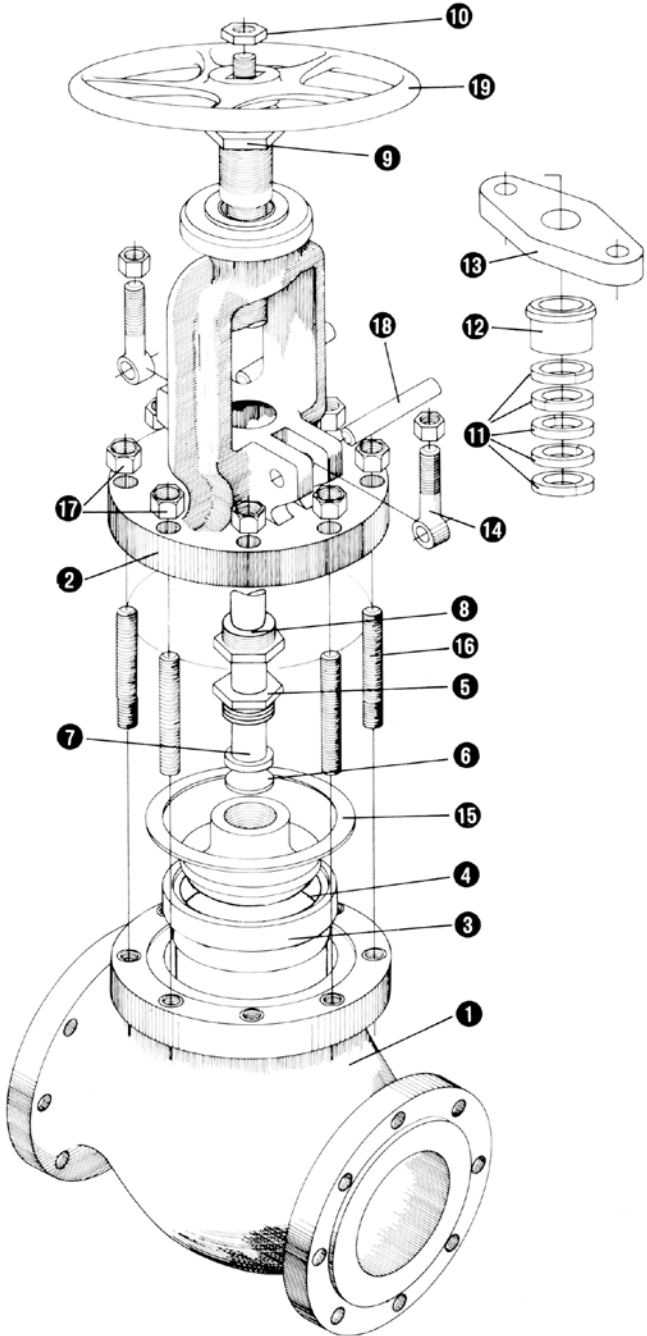

NOTE: Crane recommends the use of gear assistance for certain mult-turn valves for optimal functional performance in larger sizes and high flow-rate applications. Please refer to the note on specific product pages in the Crane Cast Steel Technical Datasheet.

Typical Swing Check Valve Features

Check valves are automatically actuated. They are opened and sustained in the open position by the force of velocity pressure, and closed by the force of gravity. Seating load and resultant tightness is dependent upon back pressure. The disc and associated moving parts may be in a constant state of movement if the velocity pressure is not sufficient to hold the valve in a wide open and stable position. Premature wear and noisy operation or vibration of the moving parts can be avoided by selecting the size of check valve on the basis of flow conditions. The minimum velocity required to hold a swing check valve in the wide open and stable position has been developed by analysis of extensive test data and is expressed by the formula:

$$v = 60\sqrt{v}$$

The value for v is equal to flow in feet per second and v is the specific volume of fluid in cubic feet per pound. Sizing swing check valves on this basis may often result in the use of valves that are smaller than the pipe in which they are used, necessitating the use of reducers for installation. The pressure

drop will be no greater than that of the larger valve that is only partially open, and valve life will be greatly extended. The added bonus, of course, is the lower cost of the smaller valve.

There is no tendency for the seating surfaces of swing check valves to gall or score, because the disc meets the flat seat squarely without rubbing contact upon closing.

Crane cast steel swing check valves are internally hung design and cannot be supplied with outside lever and weight features. This eliminates additional possible leak paths

Swing check valves are used to prevent reversal of flow in horizontal pipe lines. Crane does not recommend the use of swing check valves in vertical pipelines, however when using this style of valve in a vertical application the valve must be installed for upward flow only.

Recommended piping practice dictates that check valves be installed with a minimum of 10-15 pipe diameters distance between the check valve and any adjacent flange fitting or pump, otherwise flow fluctuation can result in damage to the valve or piping.

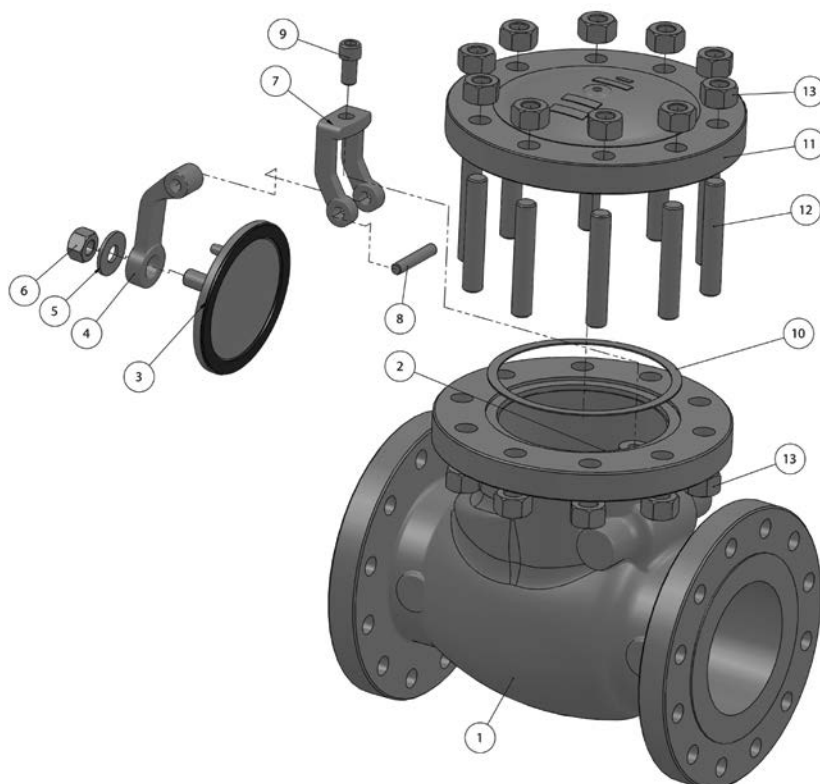

1. Body: Strong construction assures maximum safety over the recommended pressure and temperature range.
2. Seat Ring
3. Disc: Designed to close on its own weight to stop backflow from gaining sufficient velocity to create damaging shock.
4. Hinge
5. Washer
6. Disc Nut
7. Bracket
8. Hinge Pin
9. Socket Headed Cap Screw
10. Cap Gasket
11. Cap: Permits access to hinge and disc without removing valve from line.
12. Cap Stud
13. Cap Stud Nuts

For basic swing check valve illustration purposes only. This does not reflect design of the valve.

NOTE: The above sketch is generic. Valve supplied may be internal hung or external hung type units depending upon pressure class and size.

Customer Support



Customer Support

Our Cullman stocking and Long Beach locations allow us to provide:

- Responsive Customer Service for Quotes and Project Support
- Quick Ship Capabilities
- Consistent On Time Delivery
- US based Technical and Application Support
- US Country of Origin option available via Long Beach facility



Peace of Mind.

CRANE[®] Valves are a preferred supplier for OEMs, EPCs, and end users around the world because our customers know that we have a superior selection, offered in a wide array of materials, available in an almost unlimited variety of customizations. If you need a cast solution, our application engineers work with you to provide the right offering to meet your valve requirements.

CRANE®

Crane ChemPharma & Energy

CRANE Energy Global Headquarters
4526 Research Forest Drive, Suite 400
The Woodlands, Texas 77381 U.S.A.
Tel.: (1) 936-271-6500
Fax.: (1) 936-271-6510

CRANE Cast Steel Customer Service
2129 3rd Avenue, S.E.
Cullman, Alabama 35055
Tel.: (1) 256-775-3800
Fax.: (1) 256-775-3860

www.cranecpe.com

CRANE®

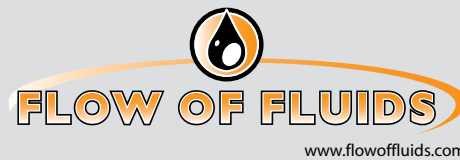

brands you trust.



COMPAC-NOZ®

CRANE®

DEPA®

ELRO® DUO-CHEK®



**KROMBACH
ARMATUREN**

NOZ-CHEK®



RESISTOFLEX®



Saunders®
the science inside

STOCKHAM®



UNI-CHEK®

w.ta.®

XOMOX®

Crane Co., and its subsidiaries cannot accept responsibility for possible errors in catalogues, brochures, other printed materials, and website information. Crane Co. reserves the right to alter its products without notice, including products already on order provided that such alteration can be made without changes being necessary in specifications already agreed. All trademarks in this material are property of the Crane Co. or its subsidiaries. The Crane and Crane brands logotype, in alphabetical order, (ALOYCO®, CENTER LINE®, COMPAC-NOZ®, CRANE®, DEPA®, DUO-CHEK®, ELRO®, FLOWSEAL®, JENKINS®, KROMBACH®, NOZ-CHEK®, PACIFIC VALVES®, RESISTOFLEX®, REVO®, SAUNDERS®, STOCKHAM®, TRIANGLE®, UNI-CHEK®, WTA®, and XOMOX®) are registered trademarks of Crane Co. All rights reserved.